



INSTALLATION INSTRUCTIONS

Accessory
19" ALUMINUM WHEEL
 P/N 08W19-STX-200C
 P/N 08W19-STX-200D

Application
2012 MDX

Publications No.
BII 46603
 Issue Date
OCT 2011

PARTS LIST

Aluminum wheel

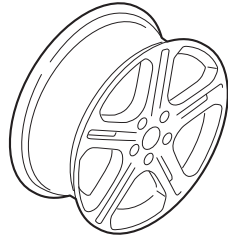

(The illustration may differ from the actual wheel.)

Wheel center cap

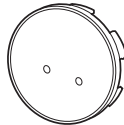

(The illustration may differ from the actual center cap.)

Center cap emblem



2 Push nuts



Tire pressure information label

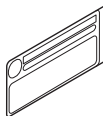

Wheel cleaning information

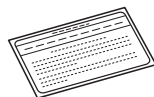

(Contained in the kit of 08W19-STX-200C only.
Give this information to your client.)

Parts for TPMS sensor assembly

Tire pressure sensor assembly



Washer



Valve cap



Valve nut



TOOLS AND SUPPLIES REQUIRED

Ratchet
 11 mm Socket
 Torque wrench
 Isopropyl alcohol
 Shop towel
 Service Manual
 HDS

SPECIFICATIONS

Rim size	19 x 8 1/2 J (offset 45)	
Tire size	255/50R19 103H	
Bolt hole PCD	120.0 (5 holes)	
Tire pressure	Front	220 kPa (2.2 kgf/cm ² , 32 psi)
	Rear	220 kPa (2.2 kgf/cm ² , 32 psi)

INSTALLATION

Client Information: The information in this installation instruction is intended for use only by skilled technicians who have the proper tools, equipment, and training to correctly and safely add equipment to your vehicle. These procedures should not be attempted by “do-it-yourselfers.”

NOTE:

- This aluminum wheel is designed for use on vehicles equipped with TPMS (Tire Pressure Monitoring System).
- This aluminum wheel is equipped with a TPMS sensor. See the service manual for the tire replacement and TPMS sensor installation procedures.
- Install the correct size tire.
- Use a tire changer to install and remove the tires as described in the operation manual furnished with the tire changer. Do not use a lever to install and remove the tires as it may cause damage to the tire and aluminum wheel.
- Do not damage the wheel center caps when installing the emblems.
- This center cap emblem should be installed only if the ambient air temperature is 15°C (60°F) or above.
- To allow the adhesive to cure, do not wash the vehicle for 24 hours. Please advise the client.

1. Before installing the tire pressure sensor, clean the mating surface and the valve hole in the aluminum wheel.

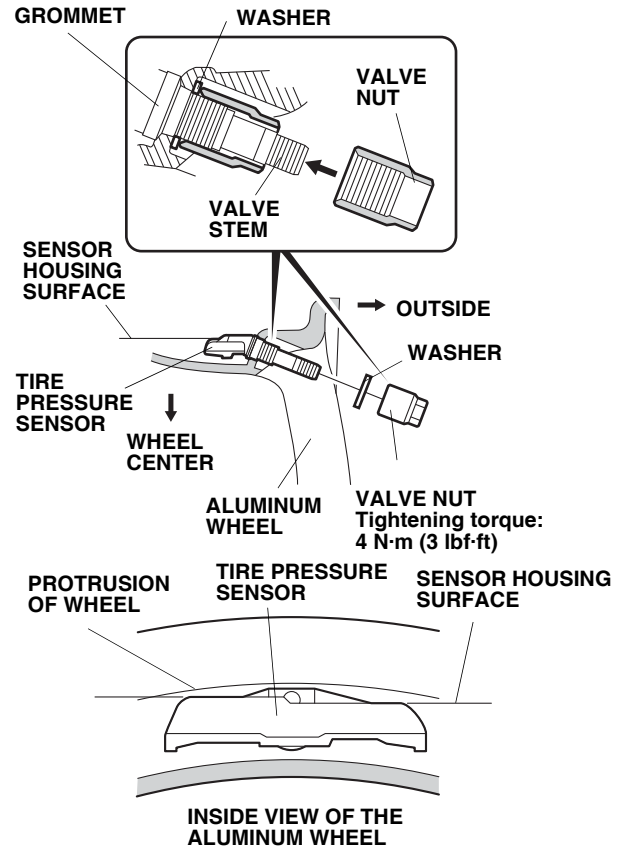

2. Install the tire pressure sensor:
 - While holding the tire pressure sensor against the rim, install the valve nut.
 - Make sure the tire pressure sensor is resting against the wheel.
 - While holding the tire pressure sensor from rotating, torque the valve nut to 4 N·m (3 lbf·ft). You may hear a pop as you torque the nut, this is normal.

NOTE:

- To prevent the sensor housing from being caught on the bead when installing the tire, install the tire pressure sensor so that the sensor housing surface does not protrude into the bead area of the wheel.
- Do not reuse grommets that have been tightened, even one time, to the specified torque, as they are deformed inside.
- Do not use pneumatic or electric tools on the valve nut.
- Tightening the nut over the specified torque can damage the grommet.

3. Install the tires according to the instructions in the service manual. Be careful not to damage the new sensors.
4. Install the center cap emblem:
 - Using isopropyl alcohol on a shop towel, clean the area where the center cap emblem will attach.
 - Remove the adhesive backing from the center cap emblem.
 - Attach the center cap emblem to the wheel center cap by aligning the pins to the holes on the wheel center cap. Hold the emblem firmly against the wheel center cap with the palm of your hand for 30 seconds.
 - Slide two push nuts onto the pins on the center cap emblem. Note the direction of the push nuts.

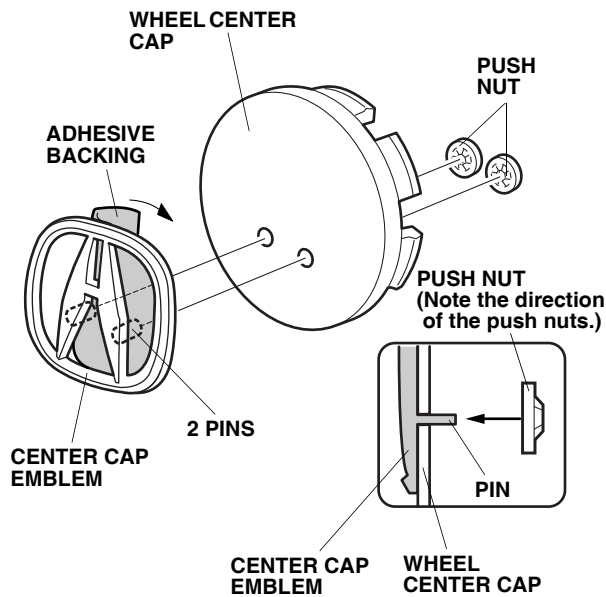

5. Install the wheels on the vehicle and torque them to 127 N·m (95 lbf·ft).
6. Install the center cap.

If the vehicle is equipped with 19" wheels, the tire pressure information label is not used, go to step 8. If not, continue with step 7.

7. Open the driver's door. Using isopropyl alcohol on a shop towel, clean the area where the tire pressure information label will attach. Remove the adhesive backing from the label, and attach it over the existing tire pressure information label.

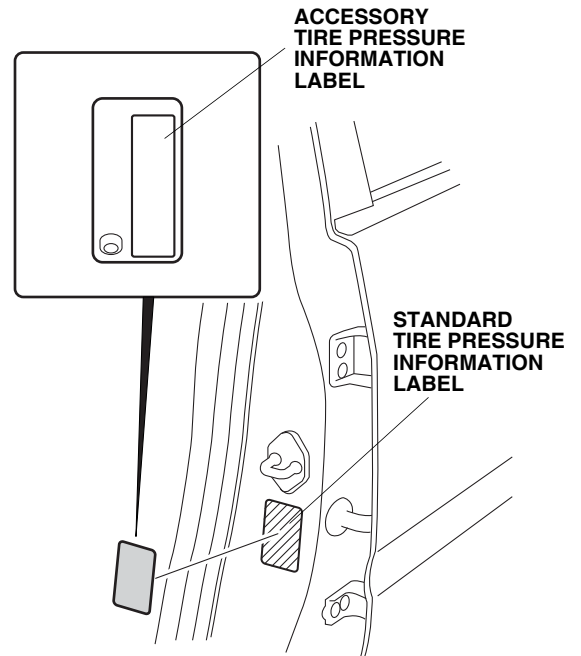

Sensor ID Learning

NOTE: Before performing the TPMS sensor ID learning, move any other TPMS sensors at least 10 feet (3 m) away from the vehicle.

8. Connect the HDS to the vehicle, make sure the correct VIN is populated, and enter the mileage.

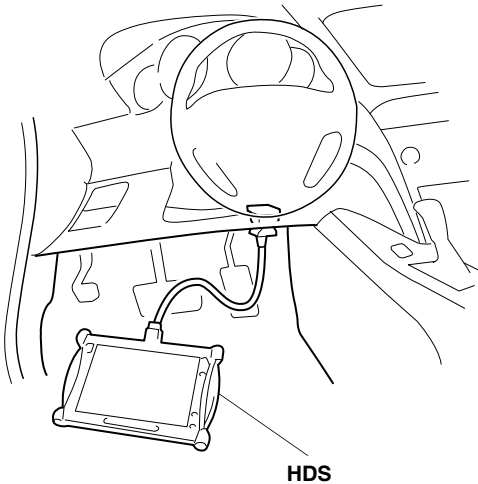

9. At the System Selection Menu, click TPMS.
10. At the Mode Menu, click DTC and clear any stored codes.
11. Go back to the Mode Menu, click Sensor ID Learning, and follow the screen prompts.

NOTE: If the ID Learning fails, have an assistant drive the vehicle under 10 mph while you start the ID learning process. The TPMS control unit should learn all four sensor IDs. If all four sensor IDs are learned, the process is complete. If one or more of the sensor IDs are not learned, go to normal troubleshooting in the service manual.

USE AND CARE

- Use a neutral detergent and water to clean the wheels.
- Rinse off the neutral detergent promptly after cleaning the wheels.

Be sure to give the wheel cleaning information (for 08W19-STX-200C wheels) to your client.